

Technical characteristics

XLS13XY

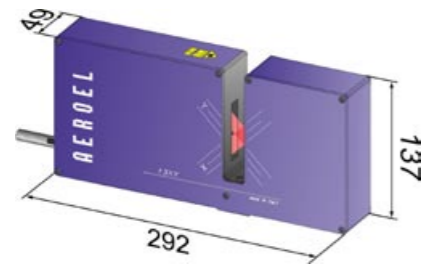

XLS35XY

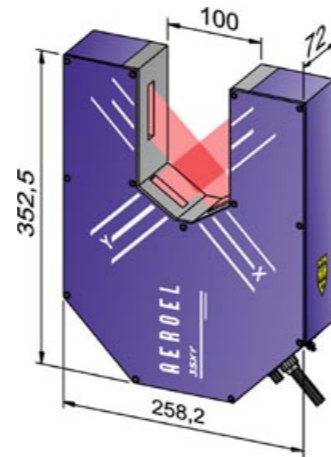

All dimensions are in mm.

ACTUM
Laser Systems

XPLORELINE.XY

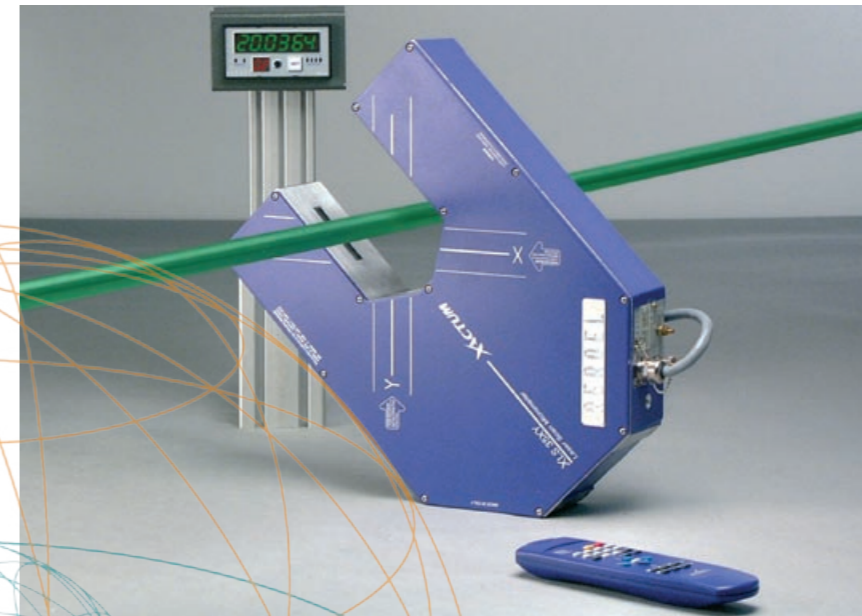

DISPLAY AND ALARMS MODULE DM-100

Main Display LED 6 digits, 7 segments multicolour
Sub Display LED 2 digit
6 Warning lights for the Status of the Inputs and the Outputs
4 Outputs protected PNP, I_{max}: 100 mA
2 Inputs PNP, I_{typ.}: 15 mA
Analog output, optional +/- 10 V
Dimensions: 97 x 49 x 158 mm
Weight: 0,5 kg
Power supply: 24 VDC 150 mA



I.R. REMOTE CONTROL

Size: 198 x 59 x 25 mm
Weight: 91 g (without batteries)
Power supply: 4 AAA 1,5 V batteries

Available models

Gauge Model	XPLORELINE.XY13		XPLORELINE.XY35
	XLS13XY	XLS13XY	XLS35XY
Beam height (mm)	13 x 13	4 x 4	35 x 35
Measurement range (mm)	From 0.16 to 10	From 0.03 to 3	From 0.2 to 32
Scanning rate (Hz)	2 x 200 / 2 x 1200		
Resolution (µm)	0.01 at best		0.1 at best
Repeatability (µm)	± 0.03 at best		± 0.2 at best
Linearity (µm)	± 0.5 at best		± 1 at best



This product conforms to the following standards:
 21 CFR 1040.10 (USA) • CEI EN-60825-1; 2003-4-1 (EU)

Use the Xactum Intelligent Laser Micrometers as on-line diameter gauges, in the Xplorelinexy configuration:
 No other instrument allows you measure diameters so quickly, so accurately and so easily.

It's the ideal instrument for the on-line diameter monitoring of continuous products like electric cable, magnet wire, optical fibers, plastic tubes, extruded profiles, glass tubes, etc.

Thanks to the Aeroel, outstanding laser technology, high accuracy, ease of use and excellent reliability are offered at affordable conditions: payback can be realized in just a few months.

Specifications subject to change without notice. For additional details and complete specifications please see the gauge data sheet.

AEROEL
 AEROEL S.R.L.
 Via Cussignacco 47, Z.I.
 Pradamano (UD)
 33040 - ITALY
 Phone +39 0432 671301
 Fax +39 0432 671543
 e-mail: aeroel@aeroel.it
<http://www.aeroel.it>



AEROEL
 PRECISION LASER SYSTEMS

The Xploreline.XY

The XLS gauges are programmed with a dedicated software and are completed with a display unit and a remote control: using such a measuring "system" you can monitor the diameter on-line, measuring fast moving products very accurately, to achieve 100% check and to avoid any dimensional non-conformity.

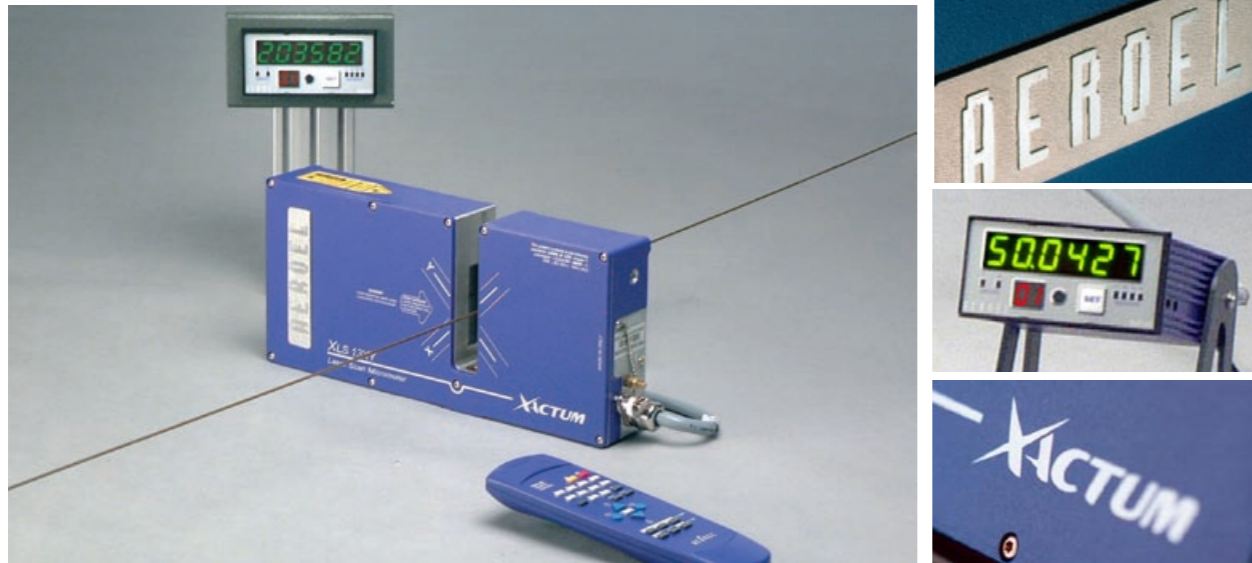

System configuration

The Xploreline.XY system is composed by:

- a dual axis Xactum gauge, XLS13XY or XLS35XY type,
- Xploreline.XY software pre loaded in the gauge,
- DM-100 multi-colour LED display,
- universal power supply,
- an I.R. Remote Control,
- connecting cable L=5m, between gauge and display.

Some optional accessories which are available:

- telescopic stand for the laser gauge,
- dust protective brackets for the gauge,
- extension cables,
- GageXcom software for PC communication.

Types of measurements

It measures the diameter D and the position C of the Center of the part, from the Center of the measuring field.

The part can be **opaque or transparent**.



Measuring modes

The gauge is continuously reading the Diameters Dx and Dy along two crossed axes and the Center Position C of the product, Cx and Cy, at a scan frequency of the gauge of 400 or 2400 Hz, depending on model. Each single scan reading is called Single Scan Value: the related measuring repeatability is specified in the gauge performance table and it is so good that any Single Scan Value can be considered to detect any flaw that turns into a diameter change.

It is possible to look for very small flaws, having a minimum length which is dependent upon the product speed and the gauge scan rate.

To improve the measuring repeatability or to filter small product irregularities, it is possible to average some N consecutive Single Scan Values and to get their average value, Instant Value; N is programmable by the user and can be as low as N=1, to make the Instant Values coincide with the Single Scan Values. The measuring repeatability of an Instant Value can be computed by dividing the single scan repeatability by the square root of the number of averaged scans N.

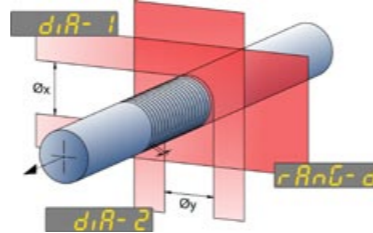

In addition it is also possible to consider a group of K⁽¹⁾ consecutive Instant Values and among them to take the Maximum and Minimum Values and to compute their Average Value⁽²⁾ and the Range=Maximum-Minimum⁽³⁾.

For instance the following values are computed and displayed: Dx, Dy, Dxy=(Dx+Dy)/2, Ovality=Dx-Dy, average Center Positions Cx and Cy, Davg, Dmax, Dmin, and Range=Dmax-Dmin⁽⁴⁾. By properly setting N and K it is possible to program the system to perform flaw detection or average diameter measurement or to measure other product dimensions that correspond to maximum and minimum values.

(1) K is programmable by the user: its minimum value is 4 for the 200 Hz gauges or 16 for the 1200 Hz gauges.

(2) The Average Value is the result of an average over N x K Instant values.

(3) The Max, Min, Avg and Range Values, computed over a group of K Instant Values, are called Extreme Values.

(4) The Dmax and Dmin values are the maximum and minimum value over K Instant values of Dx or Dy.

Measurement examples

Measuring the average diameter and looking for flaws: set N=1 and K large enough to smooth the diameter readings.

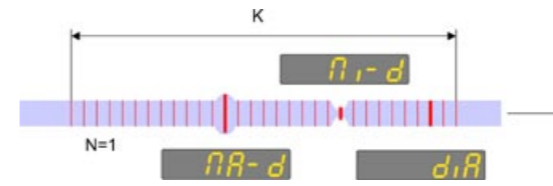

Measuring the wire diameter and ovality: the product twisting improves the accuracy

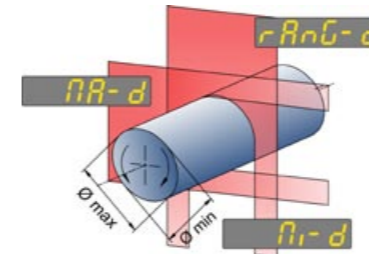

Checking corrugated product:

the peak values and the waviness can be detected.

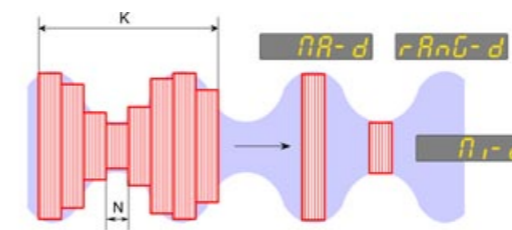

Display and remote control



Multicolour LED display to show the measured values and to allow system programming through the IR remote control.

The measured and programmed data can be scrolled on the display by using the remote control or the SET key on the display panel.

It is possible to save in memory, in a Product Library, up to 1000 different sets of programmed parameters, for each specific part to be checked

The display color will change color corresponding to the tolerance status of the shown variable (green, orange or red).



The display unit includes 4 alarm output lines to drive additional external devices.

Simple and quick programming using the remote control keys and the messages on the display.

Offset function for user re-mastering.

Selectable Measuring Unit (inch/mm) and Resolution (to 0.01µm / 1x10⁻⁶ inch).

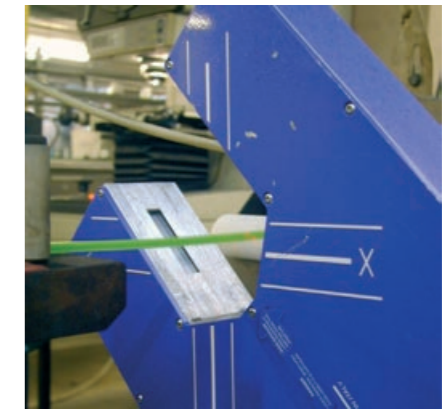

PC interface

An external / remote computer can be connected to the system through the Ethernet interface, to program the system or to get the measured data. Using the optional GageXcom software provided by Aeroel, you can use Excel spread-sheets to set-up the system and to get all measured results: you can write your own applications by processing data with the standard Excel functions.

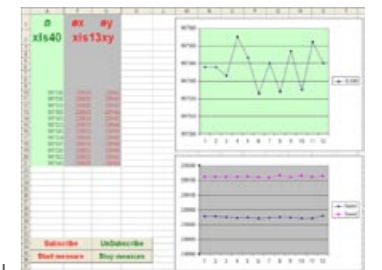

The RS232 interface can be used only one-way, just to download the measurement results; the protocol is compatible with the Aeroel's GageX software to download measured data into Excel.